

# SOLD

## GORGEOUS FAMILY HOME AWAITS YOU NOW

I am proudly presenting this gorgeous family home with all your wants and needs. The hot weather is here so many fun times ahead with your very own swimming pool. Downstairs rumpus area complete with Shower, toilet & kitchenette makes this an ideal multi function area. 2 car garage and a 3bay garage out the back offer dad lots of room for his toys.

### UPSTAIRS

- \* A/C Master Bedroom, BIW, fan and louver shutter blinds
- \* Bedroom 2 is A/C , BIW, fan and louver shutter blinds
- \* Bedroom 3 has BIW, fan and louver shutter blinds
- \* Spacious A/C living area with high ceilings
- \* Sunny kitchen has gas cooking & D/washer & good bench space
- \* Bathroom with shower centralises the home
- \* Seperate toilet
- \* Full length front patio deck for relaxing
- \* 5kw, 22 solar panels \$\$\$\$ big dollar savings

### DOWNSTAIRS

- \* Lovely sparkling above ground/inground pool, hot hot days are coming!
- \* Double remote garage underneath the house
- \* 3 bay powered shed for all dads toys
- \* Double gate side access to the rear yard
- \* Downstairs laundry adjacent to the multipurpose room
- \* Large water tank for the pool top up or the gardens
- \* Shower, toilet & kitchenette conveniently housed underneath for many purposes
- \* Colourbond fencing

Come along to the Open Home on Saturday 20th at 10am and give yourself the chance to purchase a complete family home that offers all your wants and needs all in one wonderful package. Room for dads, toys, utility or craft room for mum, large study rumpus room for the kids, shower downstairs after your big swim, big yard for the pets and above all that you have your very own pool. Imagine all the entertaining at your place with your friends and relatives celebrating your great purchase. Come along on Saturday and take in the feeling that this home could be yours. All offers are to be in by 4pm on Saturday the 20th as this house will sell .

3 BED | 2 BATH | 4 CAR

PRICE:  
\$546,000

OPEN FOR INSPECTION:  
N/A



**Mal Lucas**  
0429535197  
mal@atrealty.com.au  
[www.atrealty.com.au](http://www.atrealty.com.au)

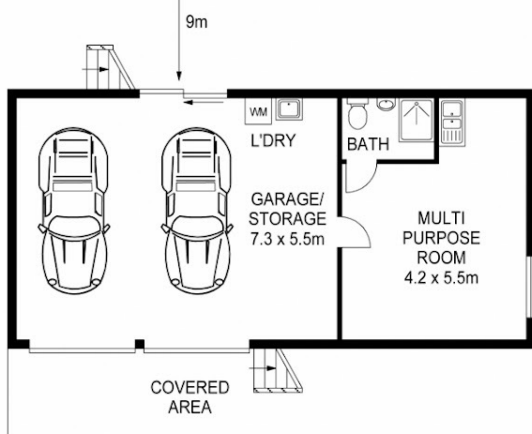
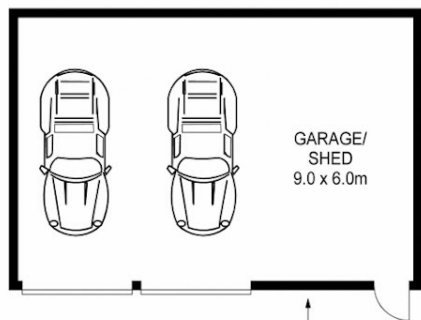

LOWER LEVEL

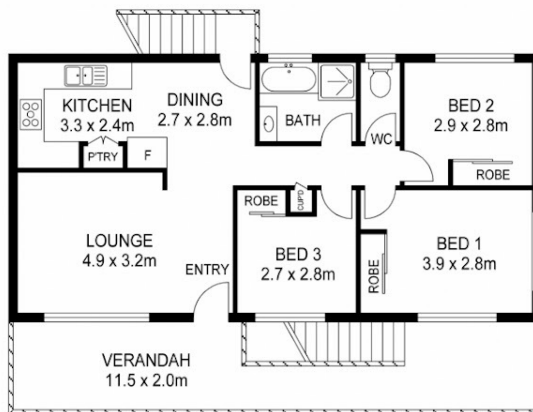

UPPER LEVEL

APPROX FLOOR AREA : 195m<sup>2</sup>

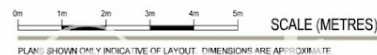

Disclaimer: Please note this floor plan is for marketing purposes and is to be used as a guide only. All dimensions are estimates only and may not be exact measurements.