

106 MCCAFFREYS ROAD, HANNAM VALE, NSW, 2443



# FOR SALE

GIVE THE KIDS THE LIFESTYLE YOU HAD  
GROWING UP - 3.9 ACRES!

This is the lifestyle so many families are craving — privacy, space, community and the simple joy of living connected to the land.

4 BED | 2 BATH | 3 CAR

PRICE:  
\$875,000

OPEN FOR INSPECTION:  
N/A



**Jenny Magill**  
**0490403051**

[jenny@magillcountryrealestate.com.au](mailto:jenny@magillcountryrealestate.com.au)  
[magillcountryrealestate.com.au](http://magillcountryrealestate.com.au)

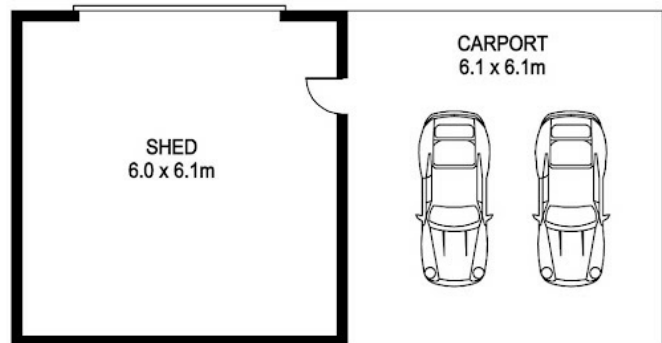
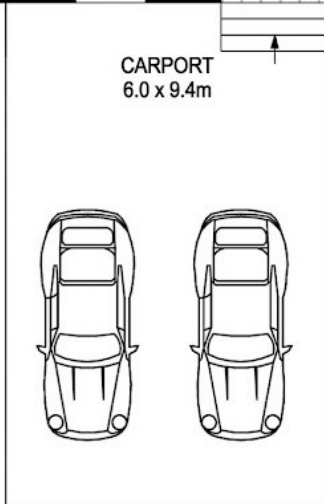

INTERNAL : 167.3m<sup>2</sup>  
 VERANDAH: 35.3m<sup>2</sup>

Disclaimer: Please note this floor plan is for marketing purposes and is to be used as a guide only. All dimensions are estimates only and may not be exact measurements.

DISCLAIMER: PLANS SHOWN ARE FOR MARKETING PURPOSES ONLY. ALL DIMENSIONS ARE APPROXIMATE AND NOT TO SCALE. THEY ARE SUBJECT TO ERRORS AND INACCURACIES AND NO LIABILITY WILL BE ACCEPTED. INTERESTED PARTIES SHOULD MAKE THEIR OWN INQUIRES.

**Jenny Magill**  
 0490403051

jenny@magillcountryrealestate.com.au  
 magillcountryrealestate.com.au

