



FOR SALE

THE FAMILY HOME THAT TICKS EVERY BOX

Positioned on a generous 809m2 fully fenced block in a peaceful Woodford location, 11 Daybell Street offers the space, comfort and versatility that today's families are searching for. Featuring four spacious bedrooms, flexible living areas, a powered shed and a fantastic entertaining deck overlooking the backyard, this is a home designed to grow with you.

Stepping inside, you'll immediately appreciate the sense of space created by the soaring raked ceilings and abundance of natural light. The open plan kitchen, living and dining area forms the heart of the home, offering a warm and welcoming atmosphere with air-conditioning for summer comfort and a cosy wood fireplace for the cooler months.

The kitchen is both practical and functional, featuring ample storage, a Chef oven, electric cooktop, Technika dishwasher and breakfast bar, making everyday family life a breeze.

Adding further flexibility, a separate living area provides the perfect space for a children's play area, study or teenagers retreat, allowing the home to adapt as your family's needs change.

Outside, the lifestyle appeal continues. The expansive covered deck overlooks the backyard and established greenery, creating the perfect setting for entertaining friends, enjoying a quiet morning coffee or simply unwinding at the end of the day.

The fully fenced yard offers plenty of room for children and pets to play, while the powered shed and double carport provide exceptional storage and vehicle accommodation for all the toys.

Offering space, versatility and a relaxed family lifestyle, this well-maintained home presents an outstanding opportunity to secure your place in the ever-popular Woodford community.

Property Features:

- Four spacious bedrooms
- Open-plan living and dining area
- Soaring raked ceilings
- Functional kitchen with breakfast bar
- Technika dishwasher
- Chef electric cooktop and oven
- Separate family / second living area

4 BED | 2 BATH | 4 CAR

PRICE:

OFFERS OVER \$869,000

OPEN FOR INSPECTION:

Jul 4 at 2:00pm - 2:30pm



Katelin Fox

0410131005

katelin@atrealty.com.au

www.atrealty.com.au

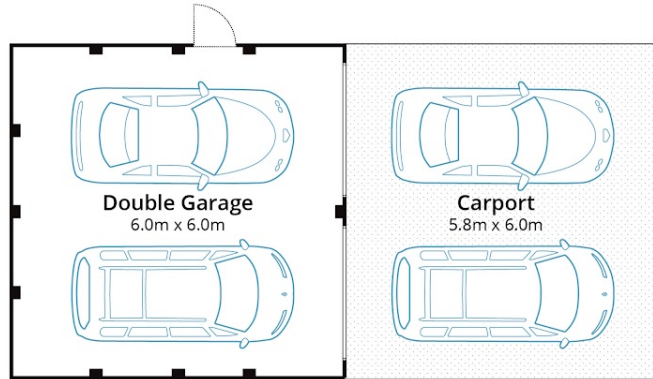
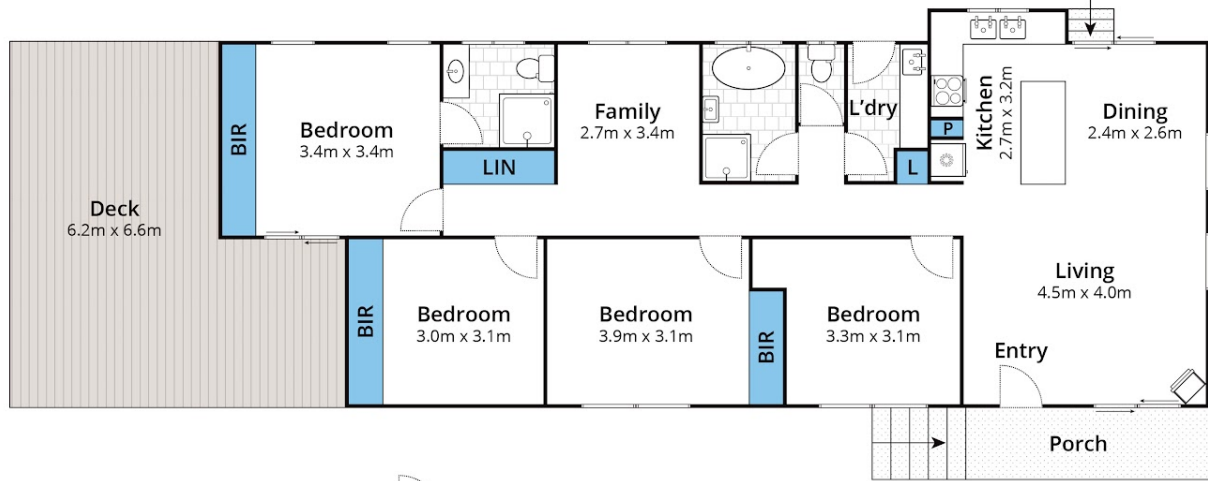

(Not In Position)

Approx House Area 116m²

Whilst bwrm.com.au has made every attempt to ensure the accuracy of the floor plan contained here, measurements are approximate and no responsibility is taken for any error, omission, or mis-statement. This plan is for illustrative purposes only.

11 Daybell Street, Woodford



Disclaimer: Please note this floor plan is for marketing purposes and is to be used as a guide only. All dimensions are estimates only and may not be exact measurements.